



Designation: D5045 – 14

# Standard Test Methods for Plane-Strain Fracture Toughness and Strain Energy Release Rate of Plastic Materials<sup>1</sup>

This standard is issued under the fixed designation D5045; the number immediately following the designation indicates the year of original adoption or, in the case of revision, the year of last revision. A number in parentheses indicates the year of last reapproval. A superscript epsilon ( $\epsilon$ ) indicates an editorial change since the last revision or reapproval.

## 1. Scope\*

1.1 These test methods are designed to characterize the toughness of plastics in terms of the critical-stress-intensity factor,  $K_{Ic}$ , and the energy per unit area of crack surface or critical strain energy release rate,  $G_{Ic}$ , at fracture initiation.

1.2 Two testing geometries are covered by these test methods, single-edge-notch bending (SENB) and compact tension (CT).

1.3 The scheme used assumes linear elastic behavior of the cracked specimen, so certain restrictions on linearity of the load-displacement diagram are imposed.

1.4 A state-of-plane strain at the crack tip is required. Specimen thickness must be sufficient to ensure this stress state.

1.5 The crack must be sufficiently sharp to ensure that a minimum value of toughness is obtained.

1.6 The significance of these test methods and many conditions of testing are identical to those of Test Method E399, and, therefore, in most cases, appear here with many similarities to the metals standard. However, certain conditions and specifications not covered in Test Method E399, but important for plastics, are included.

1.7 This protocol covers the determination of  $G_{Ic}$  as well, which is of particular importance for plastics.

1.8 These test methods give general information concerning the requirements for  $K_{Ic}$  and  $G_{Ic}$  testing. As with Test Method E399, two annexes are provided which give the specific requirements for testing of the SENB and CT geometries.

1.9 Test data obtained by these test methods are relevant and appropriate for use in engineering design.

1.10 *This standard does not purport to address all of the safety concerns, if any, associated with its use. It is the responsibility of the user of this standard to establish appro-*

*priate safety and health practices and determine the applicability of regulatory limitations prior to use.*

NOTE 1—This standard and ISO 13586 address the same subject matter, but differ in technical content.

## 2. Referenced Documents

### 2.1 ASTM Standards:<sup>2</sup>

- D638 Test Method for Tensile Properties of Plastics
- D4000 Classification System for Specifying Plastic Materials
- E399 Test Method for Linear-Elastic Plane-Strain Fracture Toughness  $K_{Ic}$  of Metallic Materials
- E691 Practice for Conducting an Interlaboratory Study to Determine the Precision of a Test Method

## 3. Terminology

### 3.1 Definitions:

3.1.1 *compact tension, n*—specimen geometry consisting of single-edge notched plate loaded in tension. See 3.1.5 for reference to additional definition.

3.1.2 *critical strain energy release rate,  $G_{Ic}$ , n*—toughness parameter based on energy required to fracture. See 3.1.5 for reference to additional definition.

3.1.3 *plane-strain fracture toughness,  $K_{Ic}$ , n*—toughness parameter indicative of the resistance of a material to fracture. See 3.1.5 for reference to additional definition.

3.1.4 *single-edge notched bend, n*—specimen geometry consisting of center-notched beam loaded in three-point bending. See 3.1.5 for reference to additional definition.

3.1.5 Reference is made to Test Method E399 for additional explanation of definitions.

### 3.2 Definitions of Terms Specific to This Standard:

3.2.1 *yield stress, n*—stress at fracture is used. The slope of the stress-strain curve is not required to be zero. See 7.2 for reference to additional definition.

<sup>1</sup> These test methods are under the jurisdiction of ASTM Committee D20 on Plastics and is the direct responsibility of Subcommittee D20.10 on Mechanical Properties.

Current edition approved Dec. 1, 2014. Published December 2014. Originally approved in 1990. Last previous edition approved in 1999 as D5045 - 99(2007)<sup>ε1</sup>. DOI: 10.1520/D5045-14.

<sup>2</sup> For referenced ASTM standards, visit the ASTM website, www.astm.org, or contact ASTM Customer Service at service@astm.org. For *Annual Book of ASTM Standards* volume information, refer to the standard's Document Summary page on the ASTM website.

\*A Summary of Changes section appears at the end of this standard

4. Summary of Test Methods

4.1 These test methods involve loading a notched specimen that has been pre-cracked, in either tension or three-point bending. The load corresponding to a 2.5 % apparent increment of crack extension is established by a specified deviation from the linear portion of the record. The  $K_{Ic}$  value is calculated from this load by equations that have been established on the basis of elastic stress analysis on specimens of the type described in the test methods. The validity of the determination of the  $K_{Ic}$  value by these test methods depends upon the establishment of a sharp-crack condition at the tip of the crack, in a specimen of adequate size to give linear elastic behavior.

4.2 A method for the determination of  $G_{Ic}$  is provided. The method requires determination of the energy derived from integration of the load versus load-point displacement diagram, while making a correction for indentation at the loading points as well as specimen compression and system compliance.

5. Significance and Use

5.1 The property  $K_{Ic}$  ( $G_{Ic}$ ) determined by these test methods characterizes the resistance of a material to fracture in a neutral environment in the presence of a sharp crack under severe tensile constraint, such that the state of stress near the crack front approaches plane strain, and the crack-tip plastic (or non-linear viscoelastic) region is small compared with the crack size and specimen dimensions in the constraint direction. A  $K_{Ic}$  value is believed to represent a lower limiting value of fracture toughness. This value has been used to estimate the relation between failure stress and defect size for a material in service wherein the conditions of high constraint described above would be expected. Background information concerning the basis for development of these test methods in terms of linear elastic fracture mechanics can be found in Refs (1-5).<sup>3</sup>

5.1.1 The  $K_{Ic}$  ( $G_{Ic}$ ) value of a given material is a function of testing speed and temperature. Furthermore, cyclic loads have been found to cause crack extension at  $K$  values less than  $K_{Ic}$  ( $G_{Ic}$ ). Crack extension under cyclic or sustained load will be increased by the presence of an aggressive environment. Therefore, application of  $K_{Ic}$  ( $G_{Ic}$ ) in the design of service components should be made considering differences that may exist between laboratory tests and field conditions.

5.1.2 Plane-strain fracture toughness testing is unusual in that sometimes there is no advance assurance that a valid  $K_{Ic}$  ( $G_{Ic}$ ) will be determined in a particular test. Therefore it is essential that all of the criteria concerning validity of results be carefully considered as described herein.

5.1.3 Clearly, it will not be possible to determine  $K_{Ic}$  ( $G_{Ic}$ ) if any dimension of the available stock of a material is insufficient to provide a specimen of the required size.

5.2 Inasmuch as the fracture toughness of plastics is often dependent on specimen process history, that is, injection molded, extruded, compression molded, etc., the specimen

crack orientation (parallel or perpendicular) relative to any processing direction shall be noted on the report form discussed in 10.1.

5.3 Before proceeding with this test method, reference should be made to the specification of the material being tested. Any test specimen preparation, conditioning, dimensions, or testing parameters, or combination thereof, covered in the relevant ASTM materials specification shall take precedence over those mentioned in this test method. If there are no relevant ASTM material specifications, then the default conditions apply.

6. Apparatus

6.1 *Testing Machine*—A constant displacement-rate device shall be used such as an electromechanical, screw-driven machine, or a closed loop, feedback-controlled servohydraulic load frame. For SENB, a rig with either stationary or moving rollers of sufficiently large diameter to avoid excessive plastic indentation is required. A suitable arrangement for loading the SENB specimen is shown in Fig. 1. A loading clevis suitable for loading compact tension specimens is shown in Fig. 2. Loading is by means of pins in the specimen holes (Fig. 3(b)).

6.2 *Displacement Measurement*—An accurate displacement measurement must be obtained to assure accuracy of the  $G_{Ic}$  value.

6.2.1 *Internal Displacement Transducer*—For either SENB or CT specimen configurations, the displacement measurement shall be performed using the machine’s stroke (position) transducer. The fracture-test-displacement data must be corrected for system compliance, loading-pin penetration (brinelling) and specimen compression by performing a calibration of the testing system as described in 9.2.

6.2.2 *External Displacement Transducer*—If an internal displacement transducer is not available, or has insufficient precision, then an externally applied displacement-measuring device shall be used as illustrated in Fig. 1 for the SENB configuration. For CT specimens, a clip gauge shall be mounted across the loading pins. For both the SENB and CT specimens measure the displacement at the load point.

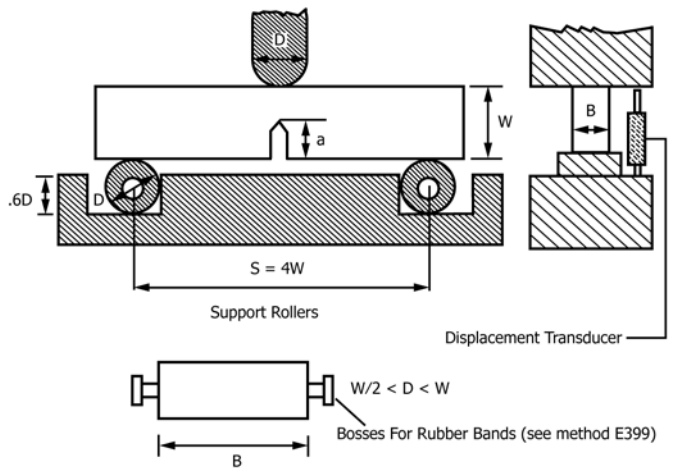

FIG. 1 Bending Rig with Transducer for SENB

<sup>3</sup> The boldface numbers in parentheses refer to the list of references at the end of these test methods.

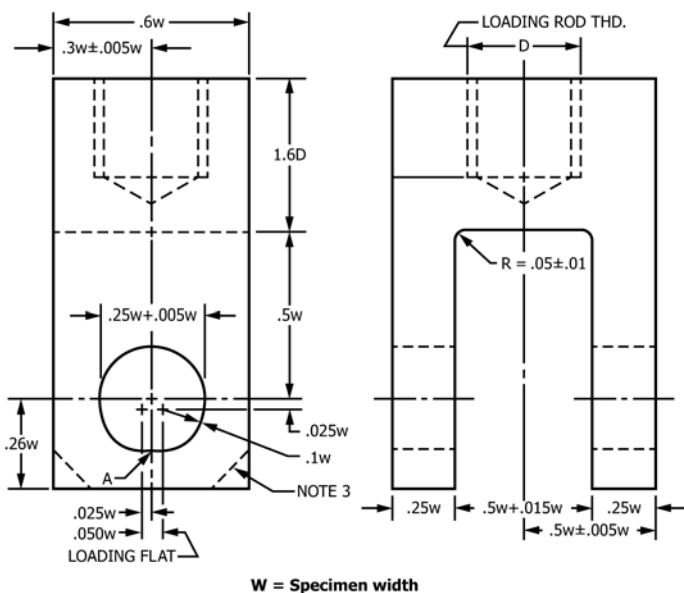

FIG. 2 Tension Testing Clevis Design for CT

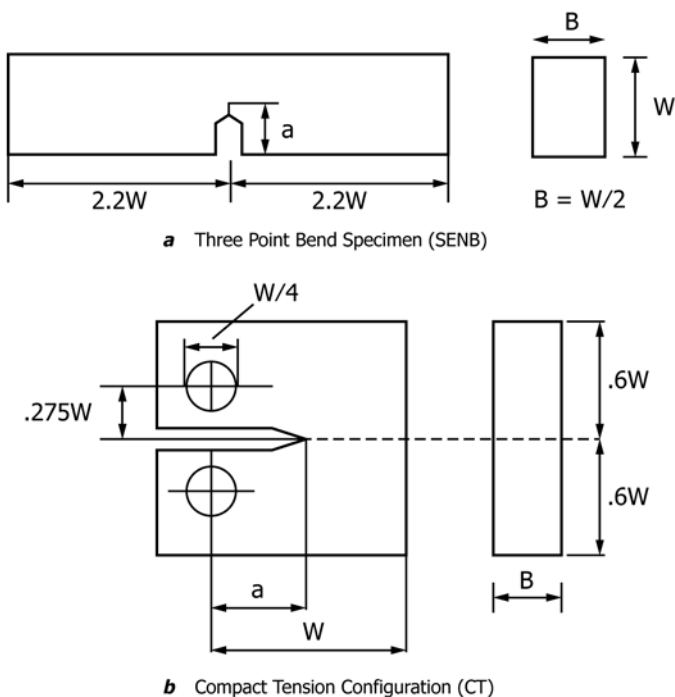

FIG. 3 Specimen Configuration as in Test Method E399

## 7. Specimen Size, Configurations, and Preparation

### 7.1 Specimen Size:

7.1.1 SENB and CT geometries are recommended over other configurations because these have predominantly bending stress states which allow smaller specimen sizes to achieve plane strain. Specimen dimensions are shown in Fig. 3 (a, b). If the material is supplied in the form of a sheet, the specimen thickness,  $B$ , is identical with the sheet thickness, in order to maximize this dimension. The specimen width,  $W$ , is  $W = 2B$ . In both geometries the crack length,  $a$ , shall be selected such that  $0.45 < a/W < 0.55$ .

7.1.2 In order for a result to be considered valid according to these test methods, the following size criteria must be satisfied:

$$B, a, (W - a) > 2.5 (K_Q / \sigma_y)^2 \quad (1)$$

where:

$K_Q$  = the conditional or trial  $K_{Ic}$  value (see Section 9), and  $\sigma_y$  = the yield stress of the material for the temperature and loading rate of the test.

The criteria require that  $B$  must be sufficient to ensure plane strain and that  $(W - a)$  be sufficient to avoid excessive plasticity in the ligament. If  $(W - a)$  is too small and non-linearity in loading occurs, then increasing the  $W/B$  ratio to a maximum of 4 is permitted for SENB specimens.

### 7.2 Yield Stress:

7.2.1 The yield stress,  $\sigma_y$ , is to be taken from the maximum load in a uniaxial tensile test. The yield-stress test can be performed in a constant stroke-rate uniaxial tensile test where the loading time to yield is within  $\pm 20\%$  of the actual loading time observed in the fracture test. The definition of yield stress is not identical to that found in Test Method D638 which requires a zero slope to the stress-strain curve. If it is established that  $2.5 (K_Q / \sigma_y)^2$  is substantially less than the specimen thickness employed, then a correspondingly smaller specimen can be used.

7.2.2 Yielding in tensile tests in most polymers can be achieved by carefully polishing the specimen sides. If yielding does not occur and brittle fracture is observed, the stress at fracture shall be used in the criteria to give a conservative size value.

7.2.3 If a tensile test cannot be performed, then an alternative method is to use 0.7 times the compressive yield stress.

7.2.4 If the form of the available material is such that it is not possible to obtain a specimen with both crack length and thickness greater than  $2.5 (K_{Ic} / \sigma_y)^2$ , it is not possible to make a valid  $K_{Ic}(G_{Ic})$  measurement according to these test methods.

7.2.5 The test method employed for determining yield stress, as mentioned in 7.2.1 – 7.2.4, must be reported.

### 7.3 Specimen Configurations:

7.3.1 Standard Specimens—The configurations of the two geometries are shown in Fig. 3(a) (SENB) and Fig. 3(b) (CT), which are taken from Annexes A3 and A4, respectively, of Test Method E399. The crack length,  $a$  (crack pre-notch plus razor notch), is nominally equal to the thickness,  $B$ , and is between 0.45 and 0.55 times the width,  $W$ . The ratio  $W/B$  is nominally equal to two.

7.3.2 Alternative Specimens—In certain cases it may be desirable to use specimens having  $W/B$  ratios other than two. Alternative proportions for bend specimens are  $2 < W/B < 4$ . This alternative shall have the same  $a/W$  and  $S/W$  ratios as the standard specimens ( $S$  = support span).

7.3.3 Displacement Correction Specimens—Separately prepared unnotched specimen configurations for the determination of the displacement correction mentioned in 9.2 are shown in Fig. 4(a) for SENB and in Fig. 4(b) for CT configurations, respectively.

### 7.4 Specimen Preparation:

a) Single edge notch bend

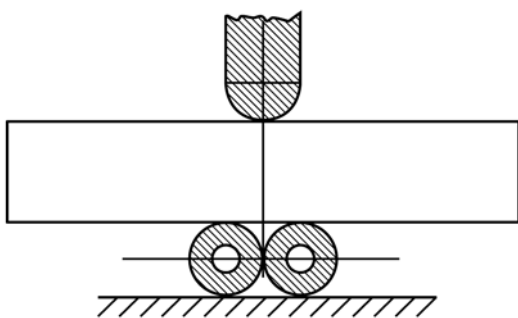

b) Compact Tension

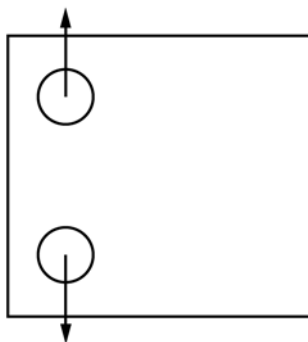

FIG. 4 Arrangements for Finding Indentation Displacement

7.4.1 Initially, prepare a sharp notch by machining. Subsequently, initiate a natural crack by inserting a fresh razor blade and tapping. If a natural crack cannot be successfully initiated by tapping, a sufficiently sharp crack shall alternatively be generated by sliding or sawing a new razor blade across the notch root. The procedure is given in 7.4.1.1 – 7.4.1.5.

7.4.1.1 Machine or saw a sharp notch in the specimen and generate a natural crack by tapping on a fresh razor blade placed in the notch.

7.4.1.2 The depth of the natural crack generated by tapping must be at least two times longer than the width of the sawed-in slot or the machined notch tip radius (notch diagram in Fig. 3 is not to scale).

7.4.1.3 If a natural crack cannot be successfully generated, either because the specimen fractures during tapping, as in some brittle materials, or because a crack cannot be seen, as in some tough materials, then in one motion or with a sawing motion slide a fresh razor blade across the machined notch.

7.4.1.4 The depth of the razor notch generated by sliding the razor blade must be two times longer than the width of the sawed-in slot or of the pre-notch tip radius (the notch diagram in Fig. 3 is not to scale).

NOTE 2—Pressing the blade into the notch is not recommended for more ductile resins because it may induce residual stresses at the crack tip which may result in an artificially high value of  $K_{Ic}$ .

7.4.1.5 The total depth of the notch obtained by machining and generation of the natural crack is the crack length,  $a$ .

8. General Procedure

8.1 Number of Tests—It is recommended that at least three replicate tests be made for each material condition.

8.2 Specimen Measurement—Specimen dimensions shall conform to those shown in Fig. 3(a, b). Three fundamental measurements are necessary for the calculation of  $K_{Ic}$  and  $G_{Ic}$ , namely, the thickness,  $B$ , the crack length,  $a$ , and the width  $W$ .

8.2.1 Measure the thickness,  $B$ , to 0.1 % accuracy at not less than three positions. Record the average of these three measurements as  $B$ .

8.2.2 Measure the crack length  $a$ , after fracture to the nearest 0.5 % accuracy at the following three positions: at the center of the crack front, and the end of the crack front on each surface of the specimen. Use the average of these three measurements as the crack length,  $a$ .

8.2.3 Measure the width,  $W$ , to within 0.1 % as described in the annex appropriate to the specimen type being tested.

8.3 Loading Rate:

8.3.1 Since plastics are viscoelastic materials, it is necessary to specify both the temperature and time scale under which the result was obtained. As a basic test condition it is recommended that a temperature of 23°C, and a crosshead rate of  $1.67 \times 10^{-4}$  m/s (10 mm/min) be used. Record both loading rate and loading time on the report form.

NOTE 3—If it is not possible to obtain valid results at 23°C, it is often possible to do so by decreasing the temperature which usually does not change  $K_{Ic}$  greatly but increases the yield stress, rendering the fracture more brittle.

8.3.2 It is recommended that speeds greater than 1 m/s or loading times less than 1 ms should be avoided because of the risk of dynamic effects causing errors.

8.4 Loading—The test is performed and the load versus loading-point displacement curve obtained. In the ideal case this is a linear diagram with an abrupt drop of load to zero at the instant of crack growth initiation. In some cases this occurs and  $K_Q$  shall be determined from the maximum load.

8.5 Load-Displacement Area—A procedure for determining  $G_{Ic}$  is included in 9.3. This requires an accurate integration of the load versus loading point displacement curve, which necessitates an accurate displacement determination using a displacement transducer. A cross check on the accuracy of  $G_{Ic}$  is provided through a corrected compliance.

9. Calculation and Interpretation of Results

9.1 Interpretation of Test Record and Calculation of  $K_Q$ —In order to establish that a valid  $K_{Ic}$  has been determined, it is first necessary to calculate a conditional result,  $K_Q$ , which involves a construction on the test record, and to then determine whether this result is consistent with the size of the specimen in accordance with 9.1.3. The procedure is given in 9.1.1 – 9.1.5.

9.1.1 Load the specimen and obtain a diagram as shown in Fig. 5. Draw a best straight line (AB) to determine the initial compliance, C. C is given by the reciprocal of the slope of line (AB). Draw a second line (AB') with a compliance 5 % greater than that of line (AB). If the maximum load that the specimen was able to sustain,  $P_{max}$ , falls within lines (AB) and (AB'), use  $P_{max}$  to calculate  $K_Q$ . If  $P_{max}$  falls outside line (AB) and line (AB'), then use the intersection of line (AB') and the load curve as  $P_Q$ . Furthermore, if  $P_{max}/P_Q < 1.1$ , use  $P_Q$  in the calculation of  $K_Q$ . However, if  $P_{max}/P_Q > 1.1$ , the test is invalid.

9.1.2 Calculate  $K_Q$  in accordance with the procedure given in A1.4 for SENB and A2.5 for CT. For this calculation, a value of  $a$ , which is the total crack length after both notching and pre-cracking, but before fracture, is best determined from the fracture surface after testing. An average value is used, but the difference between the shortest and longest length should not exceed 10 %. Take care that it is the original crack which is being observed, since slow growth can occur prior to catastrophic fast fracture.

9.1.3 Check the validity of  $K_Q$  via the size criteria. Calculate  $2.5 (K_Q/\sigma_y)^2$  where  $\sigma_y$  is the yield stress discussed in 7.2.1. If this quantity is less than the specimen thickness,  $B$ , the crack length,  $a$ , and the ligament ( $W - a$ ),  $K_Q$  is equal to  $K_{Ic}$ . Otherwise the test is not a valid  $K_{Ic}$  test.

NOTE 4—Note that use of a specimen with too small a thickness,  $B$ , will result in  $K_Q$  being higher than the true  $K_{Ic}$  value while a small ( $W - a$ ) will result in a  $K_Q$  value that is lower than the true  $K_{Ic}$  value. The net effect may be close to the correct  $K_{Ic}$  but unfortunately in an unpredictable way, since the dependence on  $B$  cannot be quantified.

9.1.4 For the recommended specimen dimensions of  $W = 2B$  and  $a/W = 0.5$ , all the relationships of 9.1.3 are satisfied simultaneously. In fact, the criterion covers two limitations in that  $B$  must be sufficient to ensure plane strain, but ( $W - a$ ) has to be sufficient to avoid excessive plasticity in the ligament. If ( $W - a$ ) is too small the test will often violate the linearity criteria. If the linearity criterion is violated, a possible option is to increase  $W$  for the same  $a/W$  and  $S/W$  ratios. Values of  $W/B$  of up to 4 are permitted.

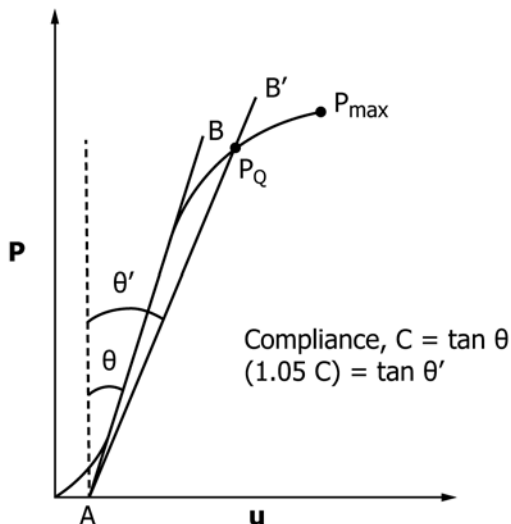

NOTE 1—C is the inverse slope of line AB.  
 FIG. 5 Determination of C and  $P_Q$

9.1.5 If the test result fails to meet the requirements in either 9.1.1 or 9.1.3, or both, it will be necessary to use a larger specimen to determine  $K_Q$ . The dimensions of the larger specimen can be estimated on the basis of  $K_Q$ , but generally must be increased to 1.5 times those of the specimen that failed to produce a valid  $K_{Ic}$  value.

9.2 Displacement Correction for Calculation of  $G_Q$ —Make a displacement correction for system compliance, loading-pin penetration, and specimen compression, then calculate  $G_{Ic}$  from the energy derived from integration of the load versus load-point displacement curve.

9.2.1 The procedure for obtaining the corrected displacement,  $u_c(P)$ , at load  $P$  from the measured displacement,  $u_Q(P)$ , is as follows: Use an un-cracked displacement correction specimen prepared from the same material as that being tested (refer to 7.3.3). Using the same testing parameters as the actual test, load the specimen to a point at or above the fracture loads observed during actual testing. From the load-displacement curve, determine  $u_i(P)$ . The corrected displacement is then calculated using  $u_c(P) = u_Q(P) - u_i(P)$  for both the SENB and CT geometries.

9.2.2 In practice, it is common to obtain a linear displacement correction curve (up to the fracture loads observed during actual testing). This simplifies the displacement correction to be applied to the fracture test. Initial non-linearity due to penetration of the loading pins into the specimen should occur during both the calibration test and the actual fracture test. Linearization of the near-zero correction data and the fracture test data can compensate for this initial non-linearity.

9.2.3 The displacement correction must be performed for each material and at each test temperature or rate. Polymers are generally temperature- and rate-sensitive and the degree of loading-pin penetration and sample compression have been found to vary with changes in these variables.

9.2.4 Perform indentation tests in such a way that the loading times are the same as the fracture tests. Since the indentations are stiffer, this will involve lower rates to reach the same loads.

9.3 Calculation of  $G_Q$ —In principle,  $G_{Ic}$  can be obtained from the following:

$$G_{Ic} = \frac{(1 - \nu^2)K_{Ic}^2}{E} \quad (2)$$

but for plastics,  $E$  must be obtained at the same time and temperature conditions as the fracture test because of viscoelastic effects. Many uncertainties are introduced by this procedure and it is considered preferable to determine  $G_{Ic}$  directly from the energy derived from integration of the load versus displacement curve up to the same load point as used for  $K_{Ic}$  and shown in Fig. 6(a, b).

9.3.1 The energy must be corrected for system compliance, loading-pin penetration, and specimen compression. This is done by correcting the measured displacement values, as shown in Fig. 6(a, b). Accordingly, if complete linearity is obtained, one form of the integration for energy is as  $U = \frac{1}{2} P_Q [u_Q - u_i]$ , where  $P_Q$  is defined in 9.1.1.

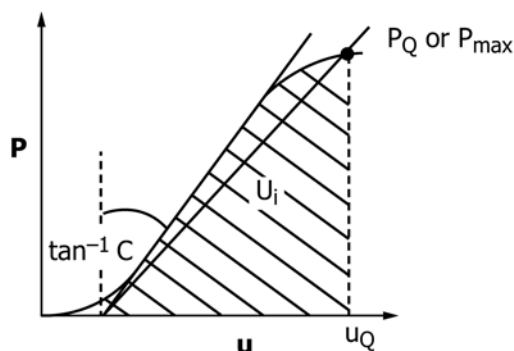

(a) LOAD - DEFLECTION IN FRACTURE TEST

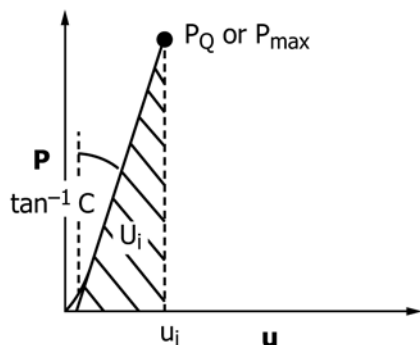

(b) LOAD - DEFLECTION IN INDENTATION

FIG. 6 Method of Correcting for Indentation

9.3.2 Alternatively, it is possible to use the integrated areas from the measured curve,  $U_Q$ , of Fig. 6(a) and indentation curves,  $U_i$ , of Fig. 6(b) in accordance with the following:

$$U = U_Q - U_i \quad (3)$$

9.3.3 Calculate  $G_Q$  from  $U$  in accordance with the procedure given in A1.4.4 for SENB and in A2.6 for CT.

9.3.4 A useful cross check on accuracy may be made using the tensile modulus,  $E$ , and Poisson's ratio,  $\nu$ .  $E/(1 - \nu^2)$  shall be calculated from the corrected compliance,  $C_c$ , using the following:

$$[E/(1 - \nu^2)] BC_c = 2f^2\phi = \Psi \quad (4)$$

in SENB. The factors  $f$ ,  $\phi$ , and  $\Psi$  are given in Table 1 and Table 2 for the two geometries. This value of  $E/(1 - \nu^2)$  shall be compared with that obtained from  $K_{Ic}^2/G_{Ic}$ . The former value should be the larger, but the difference should be <15 %. The corrected compliance,  $C_c$ , is obtained from the measured compliance in the fracture test,  $C_Q$ , and the compliance from the indentation test,  $C_i$ , in accordance with the following:

$$C_c = C_Q - C_i \quad \text{for SENB, CT} \quad (5)$$

## 10. Report

10.1 List the information required to perform the test and the results obtained in the form of a table. The form to use is provided in Table 3.

TABLE 1 Calibration Factors SENB<sup>A</sup>  $S/W = 4$

$a/W$	$f(x)$	$\phi$	$\Psi$	$\eta_e$
0.450	9.14	0.274	45.8	2.00
0.455	9.27	0.272	46.7	2.00
0.460	9.41	0.269	47.6	2.01
0.465	9.55	0.266	48.5	2.01
0.470	9.70	0.263	49.5	2.02
0.475	9.85	0.260	50.4	2.02
0.480	10.00	0.257	51.4	2.03
0.485	10.16	0.254	52.5	2.03
0.490	10.32	0.252	53.5	2.03
0.495	10.48	0.249	54.7	2.03
0.500	10.65	0.246	55.8	2.03
0.505	10.82	0.243	57.0	2.03
0.510	10.99	0.241	58.2	2.04
0.515	11.17	0.238	59.4	2.04
0.520	11.36	0.236	60.7	2.04
0.525	11.54	0.233	62.1	2.04
0.530	11.74	0.230	63.5	2.04
0.535	11.94	0.228	64.9	2.04
0.540	12.14	0.225	66.4	2.04
0.545	12.35	0.223	67.9	2.04
0.550	12.56	0.220	69.5	2.05

<sup>A</sup>Values calculated using A. Bakker, Compatibility Compliance and Stress Intensity Expressions for the Standard Three-Point Bend Specimens. Paper submitted for publication in *International Journal of Fatigue and Fracture of Engineering Materials and Structures* (March 1989).

TABLE 2 Calibration Factors Compact Tension<sup>A</sup>

$a/W$	$f(x)$	$\phi$	$\Psi$	$\eta_e$
0.450	8.34	0.208	28.9	2.64
0.455	8.45	0.207	29.6	2.63
0.460	8.57	0.207	30.4	2.61
0.465	8.70	0.206	31.1	2.60
0.470	8.83	0.205	31.9	2.58
0.475	8.96	0.204	32.7	2.57
0.480	9.09	0.203	33.5	2.56
0.485	9.23	0.202	34.4	2.54
0.490	9.36	0.201	35.3	2.53
0.495	9.51	0.200	35.3	2.53
0.500	9.65	0.199	37.1	2.51
0.505	9.81	0.198	38.0	2.50
0.510	9.96	0.197	39.0	2.49
0.515	10.12	0.196	40.0	2.48
0.520	10.28	0.194	41.1	2.47
0.525	10.45	0.193	42.1	2.46
0.530	10.62	0.192	43.3	2.45
0.535	10.80	0.190	44.4	2.44
0.540	10.98	0.189	45.6	2.43
0.545	11.17	0.188	46.8	2.42
0.550	11.36	0.186	48.1	2.41

<sup>A</sup>Values calculated using J. A. Knapp, G. S. Leger and B. Gross, Fracture Mechanics Sixteenth Symposium, *ASTM, STP 868*, 19, pp. 27–44.

## 11. Precision and Bias

11.1 Table 4 is based on a round robin conducted in 1988 in accordance with Practice E691, involving four materials tested by nine laboratories. For each material, all the samples were prepared at one source, but the individual test specimens were prepared at the laboratories which tested them. Each test result was the average of three individual determinations. Each laboratory obtained one test result for each material.

NOTE 5—The following explanations of  $r$  and  $R$  (11.2 – 11.2.3) are only intended to present a meaningful way of considering the approximate precision of this test method. The data in Table 4 should not be rigorously applied to acceptance or rejection of material, as those data are specific to the round robin and may not be representative of other lots, conditions, materials, or laboratories. Users of this test method should apply the

**TABLE 3 Testing Summary**

Fracture Test Parameters	
Testing laboratory	
Specimen preparation	
Materials/orientation	
Specimen geometry	
Test temperature, °C	
Loading rate, m/s	
Notching method	
Specimen number	
Width (W), mm	
Crack length from 7.2.2, mm	
Crack orientation relative to processing direction	
$P_{max}$ , N	
$P_{max}$ loading rate, s	
$P_O$ , N	
$P_O$ loading time, s	
Stable or unstable growth	
$K_{O_c}$ , MPa · m <sup>1/2</sup>	
Uncorrected energy, J	
Corrected energy, J	
$G_{Ic}$ , kJ/m <sup>2</sup>	
Tensile Test Parameters	
$\sigma_y$ , MPa	
$\sigma_y$ loading time, s	
Validity Checks	
$P_{max}/P_O$	
$2.5(K_{O_c}/\sigma_y)^2$	
$E/(1 - \nu^2)$ via $C$ , MPa	
$E/(1 - \nu^2)$ via $K_{O_c}^2/G_{Ic}$ , MPa	

**TABLE 4 Precision Statistics from Round-Robin Study in Accordance with Practice E691**

Material <sup>A</sup>	Average	$S_x$	$S_r$	$S_R$	$r$	$R$
A	4.34	0.652	0.235	0.679	0.658	1.90
B	5.70	1.420	0.618	1.510	1.730	4.23
C	3.60	0.692	0.343	0.747	0.960	2.09
D	5.90	1.950	0.944	2.100	2.640	7.39

<sup>A</sup>Material A is values of  $K_{Ic}$  for nylon. Material B is values of  $G_{Ic}$  for nylon. Material C is values of  $K_{Ic}$  for polycarbonate. Material D is values of  $G_{Ic}$  for polycarbonate. Units for all columns are as follows:  $K_{Ic}$  in units of MPa · m<sup>1/2</sup>.  $G_{Ic}$  in units of kJ/m<sup>2</sup>.

averages from testing three specimens, the information in 11.2.1 – 11.2.3 applies.

11.2.1 *Repeatability*,  $r$  (comparing two test results for the same material, obtained by the same operator using the same equipment on the same day)—The two test results should be judged not equivalent if they differ by more than the  $r$  value for that material.

11.2.2 *Reproducibility*,  $R$  (comparing two test results for the same material, obtained by different operators using different equipment on the same day)—The two test results should be judged not equivalent if they differ by more than the  $R$  value for that material.

11.2.3 Any judgement in accordance with 11.2.1 or 11.2.2 would have an approximate 95 % (0.95) probability of being correct.

11.3 *Bias*—There are no recognized standards by which to estimate bias of these test methods.

## 12. Keywords

12.1 critical-strain energy release rate; energy-to-break; fracture toughness; plane-strain fracture toughness

principles outlined in Practice E691 to generate the data specific to their laboratory and materials, or between specific laboratories. The principles of 11.2 – 11.2.3 would then be valid for such data.

11.2 *Concept of  $r$  and  $R$* —If  $S_r$  and  $S_R$  have been calculated from a large enough body of data, and for test results that were

## ANNEXES

### (Mandatory Information)

#### A1. SPECIAL REQUIREMENTS FOR THE TESTING OF SINGLE-EDGE NOTCH-BEND SPECIMENS

##### A1.1 Specimen

A1.1.1 The standard bend specimen is a single edge-notched beam loaded in three-point bending with a support span,  $S$ , nominally equal to four times the width,  $W$ . The general proportions of this specimen configuration are shown in Fig. 3(a).

A1.1.2 Alternative specimens having the proportion  $2 < W/B < 4$  are acceptable. These specimens shall also have a nominal support span  $S$ , equal to  $S = 4W$ .

A1.1.3 *Specimen Preparation*—For generally applicable specifications concerning specimen size and preparation see 7.1.

##### A1.2 Apparatus

A1.2.1 *Bend-Test Fixture*—The general principles of the bend-test fixture are illustrated in Fig. 1. This fixture is

designed to minimize frictional effects by allowing the support rollers to rotate and move apart slightly as the specimen is loaded, thus permitting rolling contact. Thus, the support rollers are allowed limited motion along the plane surfaces parallel to the notched side of the specimen, but are initially positively positioned against stops that set the span length and are held in place by low-tension springs (such as rubber bands).

A1.2.2 *Displacement Gauge*—For generally applicable details concerning the displacement gauge, see 6.2. For the bend specimen the displacements will be essentially independent of the gauge length up to a gauge length of  $W/2$ .

##### A1.3 Procedure

A1.3.1 *Measurement*—For a bend specimen measure the width,  $W$ , and the crack length,  $a$ , from the notched side of the specimen to the opposite side and to the crack front, respectively.

A1.3.1.1 For general requirements concerning specimen preparation see 7.4.

A1.3.2 *Bend Specimen Testing*—Set up the test fixture so that the line of action of the applied load shall pass midway between the support roll centers within 1 % of the distance between these centers. Measure the span,  $S$ , to within 0.5 % of nominal length. Locate the specimen with the crack tip midway between the rolls within 1 % of the span, and square to the roll axes within 2°.

A1.3.2.1 Load the specimen at a rate of 10 mm/min, as suggested in 8.3.1.

NOTE A1.1—A loading rate of 12.5 mm/min (0.5 in./min) shall be used if this is the only rate available.

## A1.4 Calculation

A1.4.1 *Interpretation of Test Record*—For general requirements and procedures in interpretation of the test record, see 9.1.

A1.4.2 *Validity Requirements*—For a description of the validity requirements in terms of limitations on  $P_{\max}/P_Q$  and the specimen size requirements, see 9.1.1.

A1.4.3 *Calculations of  $K_Q$* —The general formula for  $K_Q$  calculation of bend specimens is given in (3). For bend specimens with  $S/W = 4$  (Note A1.2),  $K_Q$  in units of  $\text{MPa} \cdot \text{m}^{1/2}$  is as follows:

$$K_Q = \left( \frac{P_Q}{BW^{1/2}} \right) f(x)$$

where ( $0 < x < 1$ ):

$$f(x) = 6x^{1/2} \frac{[1.99 - x(1-x)(2.15 - 3.93x + 2.7x^2)]}{(1+2x)(1-x)^{3/2}} \quad (\text{A1.1})$$

and:

$P_Q$  = load as determined in 9.1.1, kN,  
 $B$  = specimen thickness as determined in 8.2.1, cm,  
 $W$  = specimen depth (width) as determined in 8.2.3, cm, and  
 $a$  = crack length as determined in 8.2.2, cm.

$$x = a/W$$

Tabulated values of  $f(x)$  are given in Table 1.

NOTE A1.2—The expression in A1.4.3 is considered to be accurate within  $\pm 0.5$  % over the entire range of  $x$  from 0 to 1 for an  $S/W = 4$  (6).

A1.4.4 *Calculation of  $G_Q$* —For the bend specimens calculate  $G_Q$  in units of  $\text{kJ/m}^2$  from the corrected energy,  $U$ , as follows:

$$G_Q = U/(BW\phi) \quad \text{or} \quad G_Q = \eta_e U/[B(W-a)] \quad (\text{A1.2})$$

Values of  $\eta_e$  are given in Table 1. The energy calibration factor,  $\phi$ , is defined as:

$$\phi = C/[dC/d(A/W)] \quad (\text{A1.3})$$

and shall be computed from the following:

$$\phi = \frac{A + 18.64}{dA/dx} \quad (\text{A1.4})$$

where:

$$\begin{aligned} A &= [16x^2/(1-x)^2][8.9 - 33.717x + 79.616x^2 \\ &\quad - 112.952x^3 + 84.815x^4 - 25.672x^5], \text{ and} \\ dA/dx &= [16x^2/(1-x)^2][-33.717 + 159.232x \\ &\quad - 338.856x^2 + 339.26x^3 - 128.36x^4] \\ &\quad + [32x/(1-x)^3][8.9 - 33.717x + 79.616x^2 \\ &\quad - 112.952x^3 + 84.815x^4 - 25.672x^5] \end{aligned}$$

Values of  $\phi$  are given in Table 1.

## A2. SPECIAL REQUIREMENTS FOR THE TESTING OF COMPACT-TENSION SPECIMENS

### A2.1 Specimen

A2.1.1 The standard compact-tension specimen is a single edge-notched plate loaded in tension. The general proportions of this specimen configuration are shown in Fig. 3(b).

A2.1.2 Alternative specimens having the proportion  $2 \leq W/B \leq 4$  but with no change in other proportions are acceptable.

### A2.2 Specimen Preparation

A2.2.1 For generally applicable specifications concerning specimen size and preparation, see 7.1.

### A2.3 Apparatus

A2.3.1 *Tension-Testing Clevis*—A loading clevis suitable for testing compact tension specimens is shown in Fig. 2. Both ends of the specimen are held in such a clevis and loaded through pins in order to permit rotation of the specimen during testing. In order to provide rolling contact between the loading pins and the clevis holes, these holes are provided with small

flats on the loading surfaces. Other clevis designs may be used if it can be demonstrated that they will accomplish the same result as the design shown.

A2.3.1.1 The critical tolerances and suggested proportions of the clevis and pins are given in Fig. 2. These proportions are based on specimens having  $W/B = 2$  for  $B > 12.7$  mm and  $W/B = 4$  for  $B < 12.7$  mm.

A2.3.1.2 Pay close attention to achieving as good alignment as possible through careful machining of all auxiliary gripping fixtures.

### A2.4 Procedure

A2.4.1 *Measurement*—For a compact-tension specimen measure the width,  $W$ , and the crack length,  $a$ , from the plane of the centerline of the loading holes (the notched edge is a convenient reference line, but the distance from the centerline of the holes to the notched edge must be subtracted to determine  $W$  and  $a$ ). Measure the width,  $W$ , to the nearest 0.025 mm, at not less than three positions near the notch location, and record the average value.



A2.4.1.1 For general requirements concerning specimen preparation see 7.4.

A2.4.2 *Compact-Tension-Specimen Testing*—When assembling the loading train (clevises and their attachments to the tensile machine) take care to minimize eccentricity of loading due to misalignments external to the clevises. To obtain satisfactory alignment keep the centerline of the upper and lower loading rods coincident within 0.76 mm during the test and center the specimen with respect to the clevis opening within 0.76 mm.

A2.4.2.1 Load the compact-tension-specimen at a rate as specified in 8.3.1.

## A2.5 Calculation

A2.5.1 For general requirements and procedures in interpretation of the test record see 9.1.

A2.5.2 For a description of the validity requirements in terms of limitations on  $P_{\max}/P_Q$  and the specimen-size requirements see 9.1.

A2.5.3 *Calculations of  $K_Q$* —For the compact-tension specimen calculate  $K_Q$  in units of MPa·m<sup>1/2</sup> from the following expression (see Note A2.1).

$$K_Q = (P_Q/BW^{1/2})f(x) \quad (\text{A2.1})$$

where ( $0.2 < x < 0.8$ ):

$$f(x) = \frac{(2+x)(0.886+4.64x-13.32x^2+14.72x^3-5.6x^4)}{(1-x)^{3/2}}$$

where:

- $P_Q$  = load as determined in 9.1.1, kN,
- $B$  = specimen thickness as determined in 8.2.1, cm,
- $W$  = specimen width as determined in A2.4.1, cm,
- $a$  = crack length as determined in 8.2.2, cm, and
- $x$  =  $a/W$ .

Values of  $f(x)$  are given in Table 2.

NOTE A2.1—The expression in A2.5.3 is considered to be accurate within  $\pm 0.65\%$  over the range of  $a/W$  from 0.2 to 1 (6).

A2.6 *Calculation of  $G_Q$* —For the compact tension specimen calculate  $G_Q$  in units of kJ/m<sup>2</sup> from the corrected energy,  $U$ , as follows:

$$G_Q = U/(BW\phi) \quad \text{or} \quad G_Q = \eta_e U/[B(W-a)] \quad (\text{A2.2})$$

The energy-calibration factor,  $\phi$ , shall be computed from

$$\phi = \frac{(1.9118+19.118x-2.5122x^2-23.226x^3+20.54x^4)(1-x)}{(19.118-5.0244x-69.678x^2+82.16x^3)(1-x)+2(1.9118+19.118x-2.5122x^2-23.226x^3+20.54x^4)}$$

Values of  $\phi$  and  $\eta_e$  are given in Table 2.

## REFERENCES

- (1) Brown, W. F., Jr., and Srawley, J. E., “Plane Strain Crack Toughness Testing of High Strength Metallic Materials,” *ASTM STP 410*, ASTM, 1966, p. 1.
- (2) “Fracture Toughness Testing and Its Applications,” *ASTM STP 381*, ASTM, April 1965, p. 30.
- (3) Srawley, J. E., “Wide Range Stress Intensity Factor Expressions for ASTM E399 Standard Fracture Toughness Specimens,” *International Journal of Fracture Mechanics*, Vol 12, June 1976, p. 475.
- (4) Newman, J. C., “Stress Analysis of Compact Specimens Including the Effects of Pin Loading,” *ASTM STP 560*, ASTM, 1974, p. 105.
- (5) Williams, J. G., “Fracture Mechanics of Polymers,” Ellis Horwood/Wiley, 1985.
- (6) Towers, O. L., “Stress Intensity Factors, Compliances and Elastic  $\eta_e$  Factors for Six Test Geometries,” *The Welding Institute*, March 1981.

## SUMMARY OF CHANGES

Committee D20 has identified the location of selected changes to this standard since the last issue (D5045 - 99(2007)<sup>e1</sup>) that may impact the use of this standard. (December 1, 2014)

- (1) Five year review with editorial changes.
- (2) Note 1 was changed to show that ISO 13586 is no longer a CD and to conform with Guide D4968.
- (3) Replaced text in 5.3 with recommended wording from Guide D4968.
- (4) Added specimen processing and specimen orientation to Table 3.
- (5) Removed permissive language.

*ASTM International takes no position respecting the validity of any patent rights asserted in connection with any item mentioned in this standard. Users of this standard are expressly advised that determination of the validity of any such patent rights, and the risk of infringement of such rights, are entirely their own responsibility.*

*This standard is subject to revision at any time by the responsible technical committee and must be reviewed every five years and if not revised, either reapproved or withdrawn. Your comments are invited either for revision of this standard or for additional standards and should be addressed to ASTM International Headquarters. Your comments will receive careful consideration at a meeting of the responsible technical committee, which you may attend. If you feel that your comments have not received a fair hearing you should make your views known to the ASTM Committee on Standards, at the address shown below.*

*This standard is copyrighted by ASTM International, 100 Barr Harbor Drive, PO Box C700, West Conshohocken, PA 19428-2959, United States. Individual reprints (single or multiple copies) of this standard may be obtained by contacting ASTM at the above address or at 610-832-9585 (phone), 610-832-9555 (fax), or [service@astm.org](mailto:service@astm.org) (e-mail); or through the ASTM website ([www.astm.org](http://www.astm.org)). Permission rights to photocopy the standard may also be secured from the Copyright Clearance Center, 222 Rosewood Drive, Danvers, MA 01923, Tel: (978) 646-2600; <http://www.copyright.com/>*